

DOOSAN
ELECTRIC

Crawler excavator

DX300LC Electric

Rated power	145 kW
Operating weight	32,3 t
Bucket capacity	1,9 m ³



Doosan DX300LC Electric

Meet the new generation excavator

Take your business to the next level with the Doosan DX300 Electric! The Doosan DX300 Electric is very strong and completely emission-free. What do you want more?



Zero emission and higher productivity

High productivity and low cost of ownership

Higher productivity and low energy consumption in an efficient and comfortable working environment.

Reliability

Reinforced castings, forged steel pivot points, reinforced heavy-duty arm and boom to withstand high impact materials. Monoboom or articulated boom for added versatility. Improved hydraulic line routing to protect your investment.

Safety

360° camera system, large side mirrors, powerful halogen or LED worklights, antislip steps and platform. Guard rails on upper structure, ultrasonic obstruction indicator (option), travel alarm: your safety is our priority.

Productivity

State-of-the-art bucket and arm diggin forces.

Plug and play

Machine Guidance options available with major brands ready kits (Trimble, Leica, Novatron/Moba Xsite, etc.) and can differ by model and region.

Undercarriage durability

Forged steel and deep hardened top rollers, oil lubricated rollers, heat treated sprocket, deep hardened, heat-treated, grease lubricated and longer life track chains.

Employability

Deployment of 8 hours with three batteries. Based on our field test.

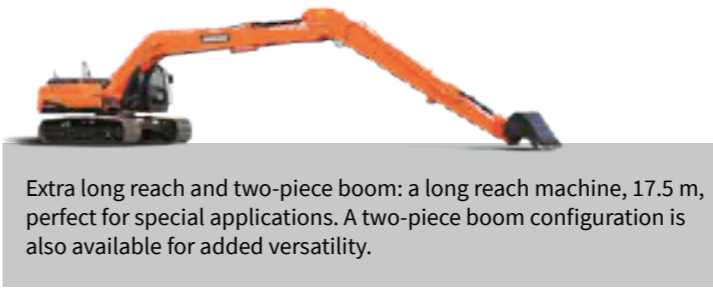

Extra long reach and two-piece boom: a long reach machine, 17.5 m, perfect for special applications. A two-piece boom configuration is also available for added versatility.

Comfort

One of the most spacious cabs in the market, with low noise and vibration levels and excellent all round visibility. Fully adjustable heated air suspension seat, air conditioning with climate control as standard.

Operate at ease

All important information is at your fingertips with the new easy to use 8" touch screen.

Electric motor

The electric motor has a high constant power specially developed for the DX300 Electric, also called PM (permanent magnet), high torque, high efficiency and maintenance-free.

Battery capacity

The available capacity of the three battery pack is 390 kWh together. The batteries are LFP modules and are equipped with a capacity meter which is visible on the standard 8" display in the cabin.

Charging time

The machine comes with CCS type 2 HV charging connector and an on-board charger of 2 x 22 kW. The charging time is 3 hours (380V/63A) or 6 hours (380V/32A) per battery pack.

Certifications

The Doosan DX300LC Electric meets the standards: CE, NEN ISO 5006, EMC, R-1000, R-10, IP65, is European certified and has Automotive approval on the components.



Perfect performance and capacity

The capacity to be more productive

The electric motor of the Doosan DX300LC Electric has a high constant power motor also called PM (permanent magnet) specially developed for the DX300LC Electric, so that the excavator can deliver a high torque hand in hand with high efficiency and is also maintenance free. With a constant power of 145 Kw | 1000 Nm continuous.

Electric motor
Consant power 145 Kw
1000 Nm continuous

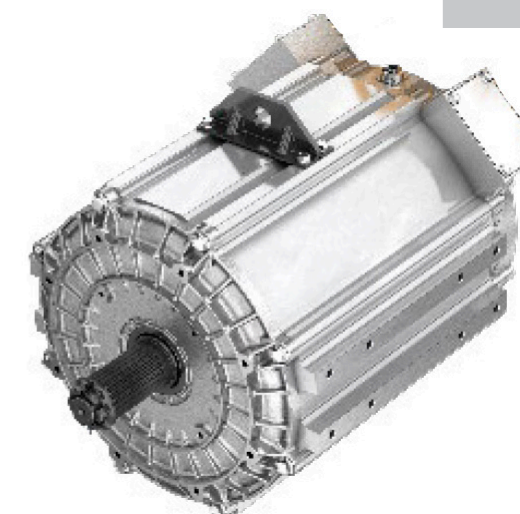

Charging options

Exchangeable battery packs

Thanks to the easily exchangeable battery packs and the fact that the machine can also run on a individual battery, it is possible to use the machine 24/7. Changing the three battery packs is therefore just as quick as refueling your diesel machine. Each battery pack consists of LFP modules. The system voltage is 650 V and the available capacity per battery pack is 130 kWh. By using the high voltage system there is less loss and greater efficiency is achieved by the batteries.

The battery packs that are in the Doosan Electric machines are one of the most important parts of the machine. We deliberately opted for a battery exchange system in the Doosan DX300LC Electric. This ensures continuous use of the machine and you can recharge where and when you want, without having to move the entire machine.

Batteries

Our batteries consist of Lithium Ion batteries of the type LFP (Lithium Iron Phosphate), which means that they are in principle 100% recyclable. An EoL (End of Life) statement is issued for the batteries. In the application as the batteries are used, they have a lifespan of 3.000 charging cycles. In practice, this equates to a lifespan of approximately ten years.

The LFP (Lithium Iron Phosphate) has many advantages. Especially the safety compared to other batteries. The battery cells cannot ignite or explode during charging. This due to the chemical stability of the iron phosphate cathode material. The battery has a long lifespan and can often be discharged and charged without affecting the performance of the battery. This composition is environmentally friendly because it does not contain toxic heavy metals or corrosive substances. The cell can also be exposed to temperatures that are high.

The second life of the batteries consists of a residential or commercial energy storage system in combination with solar panels or windmills. The batteries can have this function as an energy storage system for a period of another ten years. After this, the battery packs are at the end of their life (End of Life) and can be 100% recycled.

Charging facility

In addition to using the electric Doosan excavator, it's of course just as important to have your power supply properly arranged. It's important to check carefully in advance how the charging facility for your battery packs is arranged at the workplace. For the larger machines, you must have a charging facility for 380V. Charging from the grid with 220V is also possible, but it takes longer before your battery is fully charged again.

In the table below you can see what the charging time is at 380V and 3 different amperages:

Amperage	63A	32A	16A
Loading time per package	3 hrs	6 hrs	12 hrs

If you have a power supply at your company, you can easily have the power level adjusted to your liking by the network administrator. Our machines are standard equipped with a fast charger that allows you to charge a battery pack from empty to full in three hours (assuming you have a 380V/63A power supply).



Operating in high comfort

Best in class operator environment

The Doosan DX300LC Electric is designed to provide you with the best possible working conditions. The sophisticated state of the art ROPS cab is pressurized and ISO-certified for your safety. A high quality heated seat with air suspension provides maximum operator comfort.

First class comfort

Comfortably seated, you benefit from a clear all round view of the worksite and have easy access to several storage compartments. Noise and vibration levels are remarkably low, while air conditioning and automatic climate control allow you to keep working for hours on end without feeling tired. Pedals, joysticks and armrests have all been designed for operator comfort and efficiency.

Cab suspension

The cab's suspension system (CabSus mount) dampens vibrations and provides outstanding protection against impact. This system absorbs shocks and vibrations much more effectively than a conventional silentblock suspension system.

King - size touchscreen

The wide 8" touchscreen provides easy scrolling through the different menus, including power settings and auxiliary hydraulic settings. It also allows you to connect a Bluetooth device or listen to your favourite radio station.

360° Camera system

The 360° camera system gives you full view of the machine's surroundings.

1. Large sunroof
2. Sun visor
3. Storage compartment for sunglasses
4. Window grip
5. Improved visibility on the bottom right

6. Joysticks and switches are integrated in adjustable control consoles (option)
7. Separate seat height adjustment lever and cushion tilting function
8. Straight ergonomic pedals (option)
9. Flat, spacious, easy-to-clean floor





1. Proportional switch (option)
2. Display monitor
3. Breaker/Booster button
4. Joystick 1-touch function button
5. Starter switch (Start/Stop button) (option)
6. Electric motor speed control dial
7. Travel speed selector switch
8. Light switch
9. Cab working light switch
10. Bluetooth control panel
11. Air conditioning and heating control panel
12. Wiper control panel
13. Quick coupler switch (option)

Take a seat in business class

The ergonomic controls and the easy-to-view colour monitor place the machine firmly in your hands.

Total control in all simplicity

Dynamic power management

- Automatic travel speed range selection (slow/fast)
- Activating the power boost control system increases digging force by 10%
- A one-touch deceleration button immediately reduces engine speed low idle
- Auto-idling starts 4 seconds (adjustable) after all controls are returned to neutral - reducing the energy consumption.

Intelligente zwevende giek (option)

- The “intelligent floating boom” function allows the boom to move up and down freely according to the application:
- Hydraulic breaker setting: during boom down operation, the boom moves down freely under its own weight. The results is reduced shock, vibration and longer breaker service life.
 - Full float setting: during boom down selection, the boom is allowed to rise and fall as required while the bucket is drawn across the ground.

4 work modes and 4 power modes

- Delivers the needed power according to your specific application while minimizing energy consumption:
- 1-way mode, 2-way mode, digging mode and lifting mode
 - Power-Plus, Power, Standard or Eco

Expert fingertip control

- The new multi-function 8” touchscreen display all usefull information in a visual and intuitive format.
- At a glance, you can check the machine’s status and settings to achieve optimal efficiency.
- Doosan’s unique jog shuttle switch gives you easy and precise control over all machines functions.
- Highly sensitive and low-effort joysticks enable you to work safely, smoothly and confidently.
- The proportional thumb switches on the joysticks can be mounted horizontally or vertically, as the operator prefers, for optimal control of hydraulic attachments.



Certifications

Guaranteed safety: Everything you need to know about safety requirements and certifications

Working with electric machines requires compliance with many laws and regulations. This is extremely important to guarantee your health and safety, also for our own technicians. We would like to briefly explain some of these certifications to you.

Security requirements

Since the 1st of April 2011, electric vehicles only receive a type approval if they meet specific safety requirements when they are built electric or converted into electric powered or hybrid electric vehicles. EMC R10 automotive, IP65 and NEN ISO 5006 standards are examples of specific safety requirements. What do these certifications mean?

EMC R10 automotive

'EMC' stands for Electro Magnetic Compatibility, "R10" is a component and "automotive" stand for the motor vehicle industry. The EMC R10 Automotive certification includes a variety of approval tests. This means that a machine is tested for all European car electric regulations such as emissions and immunity.

IP

An Ingress Protection (IP)-classification is a method of indicating the degree of protection of the material of enclosures (or other objects). For example, an IP value indicates whether the material is resistant to the penetration of water, objects or dust. This is important to protect the mechanical equipment.

NEN ISO 5006-standard

This international standard specifies a test method for determining and evaluating operator visibility. Because the batteries of our electric machines are compact, the operator's field of view from his cab remains optimal.



Technical specifications

Electric motor

Permanent magnet	Motor with high constant power
Nominal power	145 kW
Maximum net torque	1000 Nm

Undercarriage

Extremely robust construction throughout - made of high quality, durable materials, with welded structures designed to limit stresses.

- Track rollers lubricated for life
- Idlers and sprockets fitted with floating seals
- Track shoes made of induction-hardened alloy with triple grouser
- Heat treated connecting pins
- Hydraulic track adjuster with shock-absorbing tension mechanism

Upper rollers (standard shoe)	2
Lower rollers	9
Number of links and shoes per side	48
Link pitch	216mm

Fluid capacities

Hydraulic oil tank	280 l
Swing drive	7 l
Travel device	2 x 7 l

Weight

	Shoe width (mm)	Machine weight (t)
Triple grouser	600 (std)	32,3
	700	33,0
	800	33,4
	850	33,5
Double grouser	900	33,0

Component weights

Item	Unit	Weight	Remarks
Upper structure without front	kg	14130	With counterweight plus 3 x battery packs
Lower structure assembly	kg	10927	
Front assembly	kg	6157	based on standard*
Boom	mm	*6245 / 6260" 2-piece boom	Including bushing
	kg	2229 / 2496	
Arm	mm	2500 / 2850 / 3100 / 3750	
	kg	967 / 1085 / 1038 / 1178	

* Standard front construction- boom 6245 mm, arm 3100 mm, universal bucket 1,9 m3.

Swing mechanism

The swing mechanism uses an axial piston motor, drive a 2-stage planetary reduction gear bathed in oil for maximum torque.

- Swing bearing: single-row, shear type ball bearing with induction hardened internal gear.
- Internal gear and pinion immersed in lubricant.

Maximum swing speed	9,88 tpm
Maximum swing torque	12137 kgf - m

Drive

Each track is driven by an independent, high torque axial piston motor through a planetary reduction gearbox. Two levers / foot pedals guarantee smooth travel with counter rotation on demand. The track frame protects the travel motor, brake and planetary gears. The multi-disc track brakes are spring-applied and hydraulic released.

Travel speed (low-high)	3,0 - 5,5 km/h
Maximum traction	35 t
Maximum gradeability	35° / 70%

Hydraulic system

The e-EPOS (Electronic Power Optimising System) is the brain of the excavator – minimising energy consumption and optimizing the efficiency of the hydraulic system for all working conditions. To harmonise the operation of the electric motor and the hydraulics, the e-EPOS is connected to the engine's electronic control unit (ECU) via a data transfer link.

- The hydraulic system enables independent or combined operations
- 2 travel speeds offer either increased torque or high speed
- Cross-sensing pump system for energy savings
- Auto-deceleration system
- 4 operating modes, 4 power modes
- Flow and pressure control of auxiliary hydraulic circuits from control panel
- Computer-aided pump flow control

Main pumps	2 x variable displacement tandem axial piston pumps
Maximum flow at 1800 rpm	2 x 248 l/min

Gear pump	
Maximum flow at 1800 rpm	27 l/min

Relief valve settings

Implement	350 (370 kgf / cm ²)
Travel	350 kgf / cm ²
Swing	295 kgf / cm ²
Pilot	40 kgf / cm ²

Hydraulic cylinders

High-strength steel piston rods and cylinder bodies. Shock absorbing mechanism fitted in all cylinders for shock-free operation and extended piston life.

Cylinders	Quantity	Bore x rod diameter x stroke (mm)
Boom	2	140 x 95 x 1450
Arm	1	150 x 105 x 1670
Bucket	1	135 x 90 x 1150
SLR Bucket	1	95 x 65 x 900
Two-piece boom	1	170 x 115 x 1341



Technical specifications

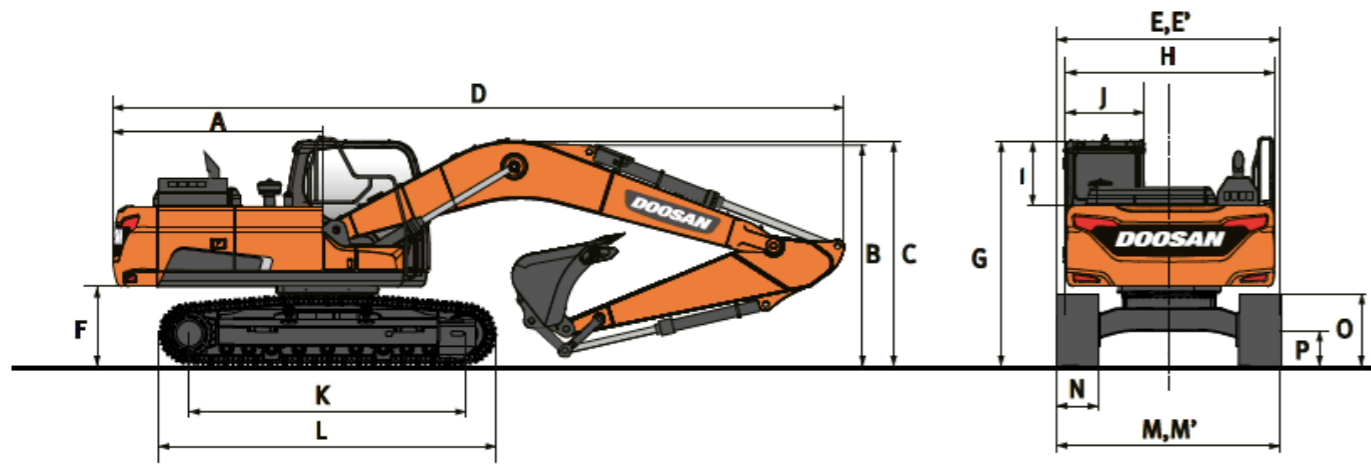

Dimensions

	Unit	One-piece boom				Two-piece boom		
		6245				3245 LB + 3050 UB		
Boom length	mm							
Arm length	mm	2500	2850	3100	3750	2500	3100	3750
Bucket capacity	m ³	1,90	1,90	1,90	1,90	1,90	1,90	1,90
A. Tail swing radius	mm	3230	3230	3230	3230	3230	3230	3230
B. Shipping height (boom)	mm	3385	3495	3265	3455	3455	3465	3700
C. Shipping height (hose)	mm	3495	3615	3370	3575	3455	3465	3700
D. Shipping length	mm	10765	10705	10605	10705	10790	10660	10660
E. Shipping width std.	mm	3200	3200	3200	3200	3200	3200	3200
E' Shipping width narrow	mm	3000	3000	3000	3000	3000	3000	3000
F. Counterweight clearance	mm	1120	1120	1120	1120	1120	1120	1120
G. Height over cab	mm	3050	3050	3050	3050	3050	3050	3050
H. House width	mm	2960	2960	2960	2960	2960	2960	2960
I. Cab height above house	mm	853	853	853	853	853	853	853
J. Cab width	mm	1010	1010	1010	1010	1010	1010	1010
K. Tumbler distance	mm	4040	4040	4040	4040	4040	4040	4040
L. Track length	mm	4940	4940	4940	4940	4940	4940	4940
M. Undercarriage width std	mm	3200	3200	3200	3200	3200	3200	3200
M' Undercarrage with narrow	mm	3000	3000	3000	3000	3000	3000	3000
N. Shoe width std.	mm	600	600	600	600	600	600	600
O. Track height	mm	970	970	970	970	970	970	970
P. Ground clearance	mm	470	470	470	470	470	470	470

Digging forces (ISO)

	Unit	One-piece boom				Two-piece boom		
		6245				3245 LB + 3050 UB		
Boom length	mm							
Arm length	mm	2500	2850	3100	3750	2500	3100	3750
Bucket capacity	m ³	1,90	1,90	1,90	1,90	1,90	1,90	1,90
Bucket (normal/press up)	ton	18,9/20,0	18,9/20,0	18,9/20,0	18,9/20,0	18,9/20,0	18,9/20,0	18,9/20,0
Arm (normal/press up)	ton	16,0/17,0	n.v.t.	13,2/13,9	11,7/12,4	16,0/17,0	13,2/13,9	11,7/12,4

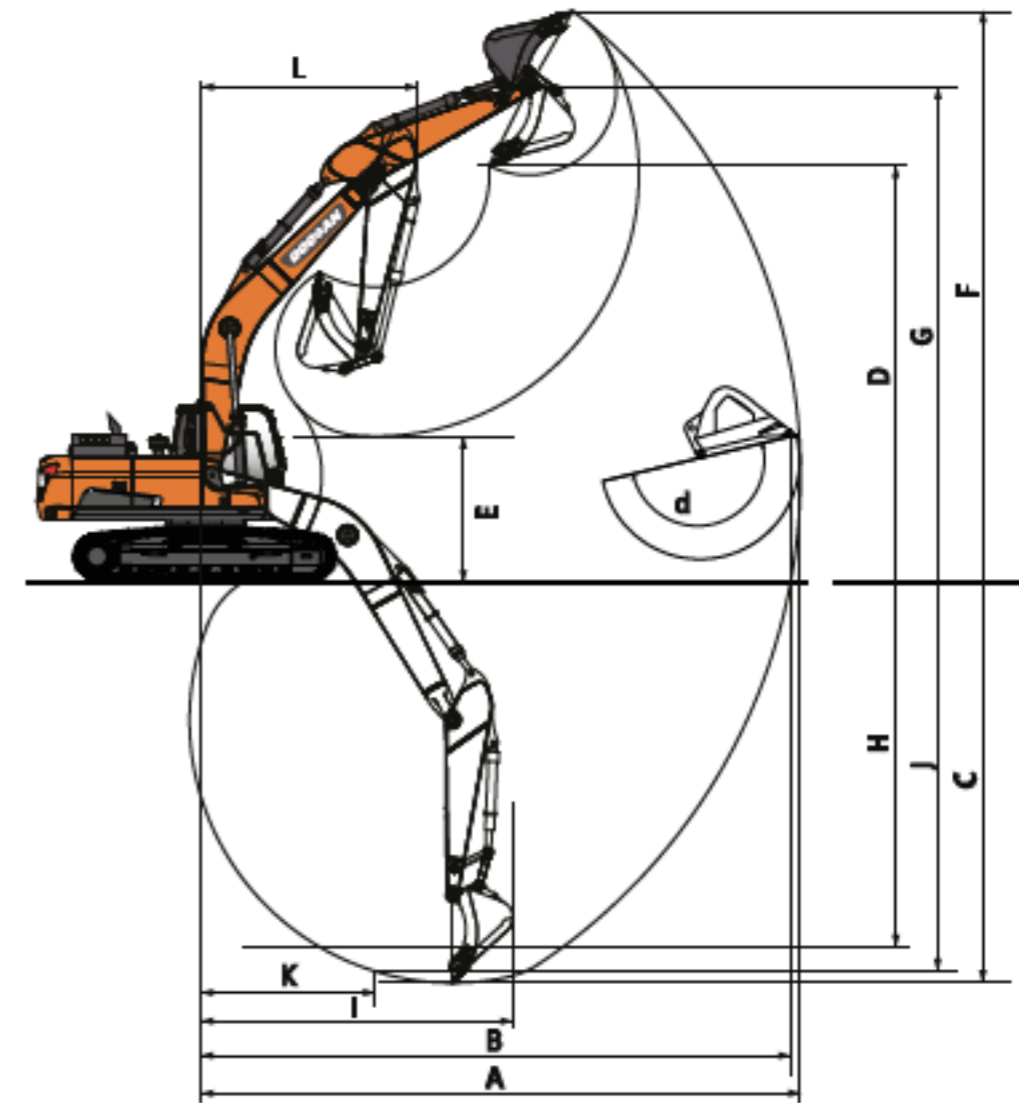

Working range

	Unit	One-piece boom				Two-piece boom		
		6245				3245 LB + 3050 UB		
Boom length	mm							
Arm length	mm	2500	2850	3100	3750	2500	3100	3750
Bucket capacity	m ³	1,90	1,90	1,90	1,90	1,90	1,90	1,90
A. Max. digging reach	mm	10155	10415	10725	11240	10860	11280	11415
B. Max. digging reach (ground)	mm	9950	10215	10530	11065	10075	10670	11235
C. Max. digging depth	mm	6700	7055	7305	7950	6410	7010	7605
D. Max. loading height	mm	6990	6995	7280	7395	8415	8895	9255
E. Min. loading height	mm	3370	3010	2750	2110	4290	3565	2950
F. Max. digging height	mm	10010	9980	10325	10405	11615	12085	12450
G. Max. bucket pin height	mm	8585	8600	8880	8990	10015	10495	10855
H. Max. vertical wall depth	mm	5395	5450	6125	6600	5185	5840	6415
I. Max. radius vertical	mm	6840	7175	6840	7070	6820	6855	7035
J. Max. digging depth (8' level)	mm	6465	6815	7110	7755	6295	6905	7517
K. Min. radius 8' level	mm	2970	2905	3000	2920	1825	1820	1820
L. Min. swing radius	mm	4045	4070	4040	4050	3065	2900	3105
d. Bucket angle	°	176	176	175	174	176	175	174

Specifications and design are subject to change without notice. Images of Doosan products may deviate from standard version.

DOOSAN

ELECTRIC